

Installation and operating instructions

Barriers P 2500 - P 5000 Part 1 of 2 Installation



Translation of original installation and operating instructions

D-ID: V1_4 – 11.15



ELKA-Torantriebe GmbH u. Co. Betriebs KG, Dithmarscher Str. 9, 25832 Tönning, Germany
E-mail: info@elka-torantriebe.de, Internet: www.elka-torantriebe.de
Telephone: +49 (0) 48 61-96 90 0, Telefax: +49 (0) 48 61-96 90 90

Index of contents

1	Preface	3
1.1	General notes	3
1.1.1	Symbol explanation	4
1.2	Copyright	4
1.3	Information regarding installation instruction	4
2	Safety	5
2.1	General notes on safety	5
2.2	Notes on safety for the operation	5
2.3	Notes on safety for the operation with radio remote control	5
2.4	Intended use – Vehicle traffic	6
2.5	Intended use – Vehicle and pedestrian traffic	6
2.6	Danger, which could emanate from the site of operation	6
2.7	Non-factory technical alterations and extensions	7
2.8	Personnel requirements – professional skills, knowledge and qualifications	7
2.9	Personal protective equipment	7
3	Transportation and storing	9
3.1	Transportation inspection	9
3.2	Scope of delivery P 2500-5000	9
3.3	Storing	9
3.4	Lifting heavy loads	10
4	Declaration of incorporation	11
4.1	Installation information for partly completed machinery	12
4.2	Declaration of conformity	12
4.3	Name plate	12
5	Function description	13
6	Technical data P 2500-5000	14
7	Installation P 2500-5000	16
7.1	Tools	16
7.2	Mounting dimensions	17
7.3	Foundation	18
7.4	Opening / closing the housing	20
7.5	Boom connector	22
7.5.1	Installation – Boom connector left side	23
7.6	Barrier boom	24
7.7	Balancing springs	25
7.8	Opening and closing times	29

7.9	Accessories	30
7.9.1	Swinging support P 4000 - P 5000	30
7.9.2	Fixed support P 4000 - P 5000	31
7.9.3	Fixed support with electromagnet P 4000 - P 5000	32
7.9.4	LED boom lighting	34
7.10	Emergency release	35
7.11	Vandalism	36
8	Terminal row	39
8.1	Interior view	39
8.2	Mains connection	39
8.3	Controller terminal row	40
8.4	Circuit diagram	43
9	Barrier maintenance	50
10	Layout (exploded drawing)	51

1 Preface

1.1 General notes

These operating instructions must be available on site at all times. It should be read thoroughly by all persons who use, or service the appliances. Improper usage or servicing or ignoring the operating instructions can be a source of danger for persons, or result in material damage. If the meaning of any part of these instructions isn't clear, then please contact ELKA-Torantriebe GmbH u. Co. Betriebs KG before you use the appliance.

This applies to all setup procedures, fault finding, disposal of material, care and servicing of the appliance. The accident prevention regulations and applicable technical regulations (e.g. safety or electrical) and environment protection regulations of the country in which the appliance is used also apply. All repairs on the appliances must be carried out by qualified persons. ELKA-Torantriebe GmbH u. Co. Betriebs KG accepts no liability for damage which is caused by using the appliance for purposes other than those for which it is built.

ELKA-Torantriebe GmbH u. Co. Betriebs KG cannot recognise every possible source of danger in advance. If the appliance is used other than in the recommended manner, the user must ascertain that no danger for himself or others will result from this use. He should also ascertain that the planned use will have no detrimental effect on the appliance itself. The appliance should only be used when all safety equipment is available and in working order. All faults which could be a source of danger to the user or to third persons must be eliminated immediately. All warning and safety notices on the appliances must be kept legible.

All electrical periphery equipment which is connected to the appliance must have a CE Mark, which ensures that it conforms to the relevant EEC regulations. Neither mechanical nor electrical alterations to the appliance, without explicit agreement of the manufacturer, are allowed. All alterations or extensions to the appliance must be carried out with parts which ELKA-Torantriebe GmbH u. Co. Betriebs KG have defined as suitable for such alterations, and be carried out by qualified personnel. Please note that with any alteration of the product, no matter whether mechanical or electrical, the warranty expires and the conformity is revoked. Only the use of ELKA accessories and original ELKA spare parts is allowed. In case of any contravention ELKA disclaims liability of any kind.



INFORMATION!

The operation of the system within CEN countries must also be conformant with the European safety-relevant directives and standards.

We reserve the right to make technical improvements without prior notice.

1.1.1 Symbol explanation

Remarks regarding the safety of persons and the gate opener itself are marked by special symbols. These remarks have to be absolutely observed in order to avoid accidents and material damage.

**DANGER!**

...points to an imminent dangerous situation, which can cause death or serious injuries if it is not avoided.

**WARNING!**

...points to a potentially dangerous situation, which can cause death or serious injuries if it is not avoided.

**ATTENTION!**

...points to a potentially dangerous situation, which can cause minor or slight injuries if it is not avoided.

**ATTENTION!**

...points to a potentially dangerous situation, which can cause property damage if it is not avoided.

**REMARK!**

Important notice for installation or functioning.

1.2 Copyright

The operating manual and the contained text, drawings, pictures, and other depictions are protected by copyright. Reproduction of any kind – even in extracts – as well as the utilization and/or communication of the content without written release certificate are prohibited. Violators will be held liable for damages. We reserve the right to make further claims.

1.3 Information regarding installation instruction

This document is to be used as installation instruction for partly completed machinery (according to machinery directive 2006/42/EG, article 13, (2)).

2 Safety

2.1 General notes on safety

The valid regulations and standards have to be observed during installation and operation, e.g. DIN EN 13241-1, DIN EN 12445, DIN EN 12453 etc. Only the use of spare parts made by the original manufacturer is allowed.

Do not put a defective barrier into operation.

After set-up (installation) every user of the equipment has to be instructed about the operation and function of the barrier.

In order to reduce the risk potential related to the movement of the barrier boom, additional optical and/or acoustical warning devices should be installed.

2.2 Notes on safety for the operation

Children and not instructed persons are not allowed to operate the barrier.

No persons, objects, or animals are allowed within the range of the barrier movement during opening or closing.

Never reach into moving parts of the barrier.

Drive through the barrier only after complete opening.

The barrier has to be secured depending on the type of usage, corresponding to the valid standards and regulations.

The safety devices have to be checked regularly for functioning according to the standards and regulations, at least twice a year.

2.3 Notes on safety for the operation with radio remote control

The radio remote control should only be used, if the area of movement of the barrier is always completely visible by the operator and thus it is assured, that no person, object, or animal is present within this range of movement.

The radio remote control transmitters have to be carefully kept, so that an unintentional use is impossible.

Radio remote controls should not be operated at radio-technical sensitive locations, like airports or hospitals.

Interferences by other (properly operated) radio communication installations, which are used within the same frequency range, cannot be ruled out.

2.4 Intended use – Vehicle traffic

The operational safety can only be ensured when the barrier is used as intended.

After installation, the barriers of the series P 2500-5000 serve as passage control of vehicle paths.



CAUTION!

Danger of impact and crushing!

With inadequate safety measures the movement of the barrier boom can result in impact or crushing points between the boom and solid objects within the movement area.

- In order to reduce the potential danger during the barrier boom movement, additional optical and/or acoustic warning devices should be installed.

The controller is a product component and serves to control the barrier.

Any use above and beyond the above mentioned use is prohibited and constitutes improper use.

2.5 Intended use – Vehicle and pedestrian traffic

The operational safety can only be ensured when the barrier is used as intended.

After installation, the barriers of the series P 2500-5000 serve as passage control of vehicle paths.



CAUTION!

Danger of impact and crushing!

With inadequate safety measures the movement of the barrier boom can result in impact or crushing points between the boom and solid objects within the movement area.

- In order to reduce the potential danger during the barrier boom movement, additional optical and/or acoustic warning devices should be installed.
- At least one safety photoelectric barrier for pedestrian presence detection has to be installed.

The controller is a product component and serves to control the barrier.

Any use above and beyond the above mentioned use is prohibited and constitutes improper use.

2.6 Danger, which could emanate from the site of operation

The barriers P 2500-5000 operate with moving parts.



WARNING!

Rotating and/or linear movable components can cause serious injuries.

Do not reach into moving parts or handle any moving components during operation.

- Turn the appliance off before any maintenance work, repair work or other work and secure it against unintentional restarting.

2.7 Non-factory technical alterations and extensions

Non-factory technical alterations and/or extensions may result in hazards as well as interfere with the function of the barrier.



DANGER!

Danger through voltage!

Risk of death by electric shock!

- Technical alterations may only be performed by skilled personnel and only according to the manufacturer's instructions.



CAUTION!

Danger of injury through defective components!

Mechanical and electrical alterations can influence the functioning of the barrier!

- Technical alterations may only be performed by skilled personnel and only according to the manufacturer's instructions.



CAUTION!

Malfunctioning of the barrier!

Mechanical and electrical alterations can influence the functioning of the barrier!

- Technical alterations may only be performed by skilled personnel and only according to the manufacturer's instructions.

2.8 Personnel requirements – professional skills, knowledge and qualifications



WARNING!

Risk of injury through inadequate qualification!

Improper handling during installation, maintenance, repair work or dismantling can result in personal injury and/or property damage.

- Work during installation, maintenance, repair and dismantling must be performed by skilled personnel only.

Specialist - is a person with suitable professional training, knowledge and experience, who can recognize and avoid danger.

Instructed person - is a person, which was instructed in the operation and use of the barrier.

2.9 Personal protective equipment

During installation, maintenance, repair work and dismantling of the barrier suitable personal protective equipment must be worn.



CAUTION!

Bruising/jamming/driving over (e.g. by material handling equipment, industrial trucks) the feet, contusion by falling heavy objects, cutting injuries by stepping into pointed/sharp objects.

Foot injuries

- Wearing of suitable safety shoes during the installation, maintenance, repair work and dismantling protects against serious foot injuries with long-lasting consequences.

**CAUTION!****Falling heavy objects hitting the head**

Head injuries

- Wearing of a suitable safety helmet during the installation, maintenance, repair work and dismantling protects against serious head injuries with long-lasting consequences.

**CAUTION!****Cutting injuries resulting from pointed/sharp objects**

Hand injuries

- Wearing of suitable safety gloves during the installation, maintenance, repair work and dismantling protects against serious hand injuries with long-lasting consequences.

**CAUTION!****Injuries resulting from drilling chips or saw dust**

Eye injuries

- Wearing of suitable safety goggles during the installation and repair work protects against serious eye injuries with long-lasting consequences.

3 Transportation and storing

3.1 Transportation inspection

The shipment has to be inspected for transportation damage immediately after receipt. In case of any damage record the type and extent on the delivery receipt or refuse acceptance.

Inform ELKA-Torantriebe immediately in the event of damage.

In case the above points are not observed claims will be denied due to insurance regulations.

3.2 Scope of delivery P 2500-5000

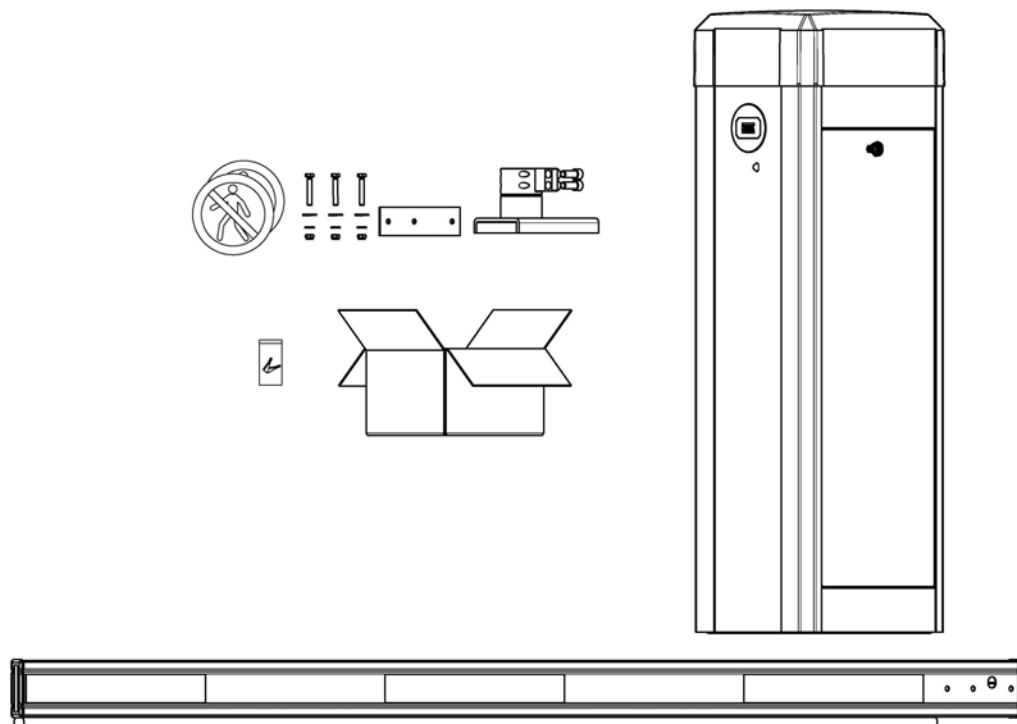

Drawing 1

Scope of delivery:

- 1x barrier model P 2500-5000
- 1x barrier boom
- 2x keys (in a pouch) for the access panel
- 1x accessory box with:
 - 2x warning signs "No passage for pedestrians"
 - 3x plastic screws or 3x steel screws for P 5000 incl. washers and nuts for the boom connection
 - 1x boom connector incl. reinforcement plate and fastening screws

3.3 Storing

The barrier has to be stored as follows:



CAUTION!

Do not expose the barrier to aggressive substances.



CAUTION!
Do not expose the barrier to heat sources.



CAUTION!
Storage temperature -30°C to +70°C / -22°F to +158°F.

3.4 Lifting heavy loads



WARNING!
Risk of injury by lifting heavy loads!
Lifting heavy loads may cause serious injuries.

- Never lift the barrier single-handedly.
- To lift the barrier, use a suitable lifting device.
- Wear suitable safety shoes.

Barrier model	Weight barrier without boom [kg]	Weight standard boom / round boom [kg]	Total(with standard boom / round boom) [kg]
P 2500	57	3.8 / 2.0	60.8 / 59.0
P 3000	58	4.5 / 2.4	62.5 / 60.4
P 3500	58	5.0 / 2.8	63.0 / 60.8
P 4000	59	5.8 / 3.2	64.8 / 62.2
P 5000	60	10.0 / ---	70.0 / ---

Table 1

4 Declaration of incorporation



**Declaration of incorporation
for the installation of a partly completed machinery
according to EC Machinery Directive 2006/42/EC, annex II part 1 B**

The manufacturer ELKA-Torantriebe GmbH u. Co. Betriebs KG
Dithmarscher Str. 9
25832 Tönning, Germany

We herewith declare that the partly completed machinery

Product description: Barrier
Function: Barrier for passage control of traffic ways
Type designation: P 2500, P 3000, P 3500, P 4000, P 5000
Serial number: 814002500150101 to 814002504155299 for P 2500
814003000150101 to 814003004155299 for P 3000
814003500150101 to 814003504155299 for P 3500
814004000150101 to 814004004155299 for P 4000
814005000150101 to 814005002155299 for P 5000

Year of manufacture: 2015

complies with the essential requirements of the following directive, as far as possible with the scope of delivery (see attachment for information regarding which requirements are met)

2006/42/EG	Machinery Directive
2006/95/EG	Low Voltage Directive
2004/108/EG	EMC-Directive

The following harmonized standards are applied:

EN ISO 12100-2:2004	Safety of machinery - Basic concepts, general principles for design - Part 2: Technical principles
EN 60204-1: 2007	Safety of machinery - Electrical equipment of machines - Part 1: General requirements
EN 60335-1: 2002, +A11 (2004) +A12 (2006) +A2 (2006) +A13 (2008) +A14 (2010)	Safety of household and similar electrical appliances, part 1 General requirements, resultant:
EN 61000-3-2: 2006, +A1 (2009) +A2 (2009)	Limits for harmonic current emissions
EN 61000-3-3: 2008	Limits - Limitation of voltage changes, voltage fluctuations and flicker
EN 61000-4-2: 2009	Electrostatic discharge immunity test
EN 61000-4-3: 2006, +A1 (2008) +A2 (2010)	Electromagnetic field immunity test
EN 61000-4-4: 2004, +A1 (2010)	Electrical fast transient/burst immunity test
EN 61000-4-5: 2006	Surge immunity test
EN 61000-4-6: 2009	Immunity to conducted disturbances, induced by radio-frequency fields
EN 61000-4-11: 2004	Voltage dips, short interruptions and voltage variations immunity tests
EN 61000-4-13: 2002, +A1 (2009)	Harmonics and interharmonics including mains signalling at a.c. power port, low frequency immunity tests
EN 61000-6-2: 2005	Generic standards - Immunity for industrial environments
EN 61000-6-3: 2007, +A1 (2011)	Generic standards - Emission standard for residential, commercial and light-industrial environments
EN ISO 13849-1:2008	Safety of machinery. Safety related parts of control systems

Further we declare that the special technical documentation for this partly completed machinery is compiled in accordance with annex VII part B, and we undertake to transmit relevant information to the market surveillance authorities upon request.

The partly completed machinery must not be put into service until it is incorporated into a machinery, which has been declared in conformity with the provisions of the EC Machinery Directive and for which an EC declaration of conformity according to annex II A was issued.

Empowered to draw up the declaration:
ELKA-Torantriebe GmbH u. Co. Betriebs KG, Dithmarscher Str. 9, 25832 Tönning, Germany

Tönning, 02.01.2015

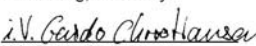
 i.V. Guido Christiansen
 Dipl.-Ing. (FH)
 Chief Engineer

Attachment

Requirements of annex I of 2006/42/EG which are met. The numbers relate to the chapters of annex I:

1.1.2., 1.1.3., 1.1.5., 1.1.6., 1.2.1., 1.2.3., 1.2.4., 1.2.6., 1.3.1., 1.3.2., 1.3.4., 1.3.8., 1.3.9., 1.5.1., 1.5.6., 1.5.11., 1.6.1., 1.6.3., 1.7.1. (partially), 1.7.2., 1.7.3., 1.7.4. (partially)

Drawing 2

4.1 Installation information for partly completed machinery

The partly completed machinery must not be put into service until the final machinery into which it has to be incorporated has been declared in conformity with the provisions of the machinery directive.



The safety functions of the controller comply with EN ISO 13849-1:2008 Kat.2 PLc.



According to EC Directive 2006/42/EG the mains supply has to be equipped with an all-pole circuit breaker.



WARNING!

Danger through voltage!

Danger of an electric shock.

- Only certified electricians (VDE 0100) should connect the controller to the mains supply.



According to DIN EN 12453, for an application with passenger traffic, depending on the type of use and type of activation, suitable safety devices have to be installed additionally, in order to provide the minimum level of protection.

4.2 Declaration of conformity

After the installation an EG- declaration of conformity according to EC- machinery directive 2006/42/EG for the complete system has to be issued by the person responsible for the integration (according to product standard DIN EN 13241-1).

4.3 Name plate

The name plate of the barrier is attached at the inside front of the barrier housing.

5 Function description

Barriers serve as passage control of vehicle paths. By raising and lowering of the barrier boom the passage is granted or obstructed.

For a boom length of 4,000mm we recommend the use of a fixed or swinging support, for a boom length of more than 4,000mm the use of a fixed or swinging support is mandatory.

The controller offers the possibility to activate the barrier by radio remote control.

The controller is able to observe the max. permitted force which was set before in the learning sequence. If during the closing movement more force is needed, the barrier reverses. Additionally several different safety features, e.g. photoelectric barriers, can be connected.



CAUTION!

Danger of impact and crushing!

With inadequate safety measures the movement of the barrier boom can result in impact or crushing points between the boom and solid objects within the movement area.

- In order to reduce the risk potential related to the movement of the barrier boom, additional optical and / or acoustic warning devices should be installed.

6 Technical data P 2500-5000

Range of application	
Application for...	<ul style="list-style-type: none"> • Parking garages, parking areas and camping sites • Company entrances
Drive pulse from...	<ul style="list-style-type: none"> • TCP/IP • RS485 • Push button, card reader, desktop panel etc. • Transmitter (radio remote control) • Induction loops
Safety	<ul style="list-style-type: none"> • Force monitoring for barrier CLOSE • Emergency release / vandalism protection • Internal evaluation for safety contact profile (8.2kOhm) • Connection of external safety systems

Table 2



General data	
Supply voltage	88~264VAC 47~63Hz
Current consumption	Max. 1.4A (230VAC) Max. 2.8A (115VAC)
Duty cycle	100%
Temperature range	 -30°C or -22°F to  +70°C or +158°F
Controller	MO 24
Housing dimensions (L/W/H)	360x300x1.100mm
Foundation (frost-free)	550x500x800mm
Boom connector	Left or right
Housing	Aluminium
Mechanics	Steel, galvanized
Sound pressure level (distance 1m)	≤ 60 dB(A)
Degree of protection	IP54

Table 3

Model-related data	P 2500	P 3000	P 3500	P 4000	P 5000
Power consumption, max. [W]	180	85	80	85	195

Running time - standard, ca. [s]	1.3	1.8	2.5	3.8	4.5
Running time - slow, ca. [s]	1.8	2.5	3.8	4.5	5.5
Running time - fast, ca. [s]	0.9	1.3	1.8	2.8	3.8
Max. boom length [mm]	2,500	3,000	3,500	4,000	5,000
Effective boom length [mm]	2,280	2,780	3,280	3,780	4,780
Power reversal	yes	yes	yes	yes	yes

Table 4

7 Installation P 2500-5000

7.1 Tools

Quantity	Description	
2	Open-end wrench	13mm
1	Open-end wrench	16mm
1	Open-end wrench	17mm
1	Open-end wrench	18mm
1	Open-end wrench	19mm
1	Allen key	6mm
1	Torque wrench (1-25Nm)	1/4"-square head
1	Bit	1/4", 13mm
1	Torque wrench (40-200Nm)	3/4"-square head
1	Bit	3/4", 10mm, Length 100mm
1	Bit	3/4", 19mm, Length 100mm
1	Bit	3/4", 10mm, hexagon socket, length 100mm
1	Right-angle screwdriver for hexagon socket screws	4mm, long model
1	Right-angle screwdriver for hexagon socket screws	6mm, long model
1	Screwdriver	0,6 x 3,5mm
1	Screwdriver	PH2 x 100
1	Cutter knife	18mm
1	Level	

Table5

7.2 Mounting dimensions

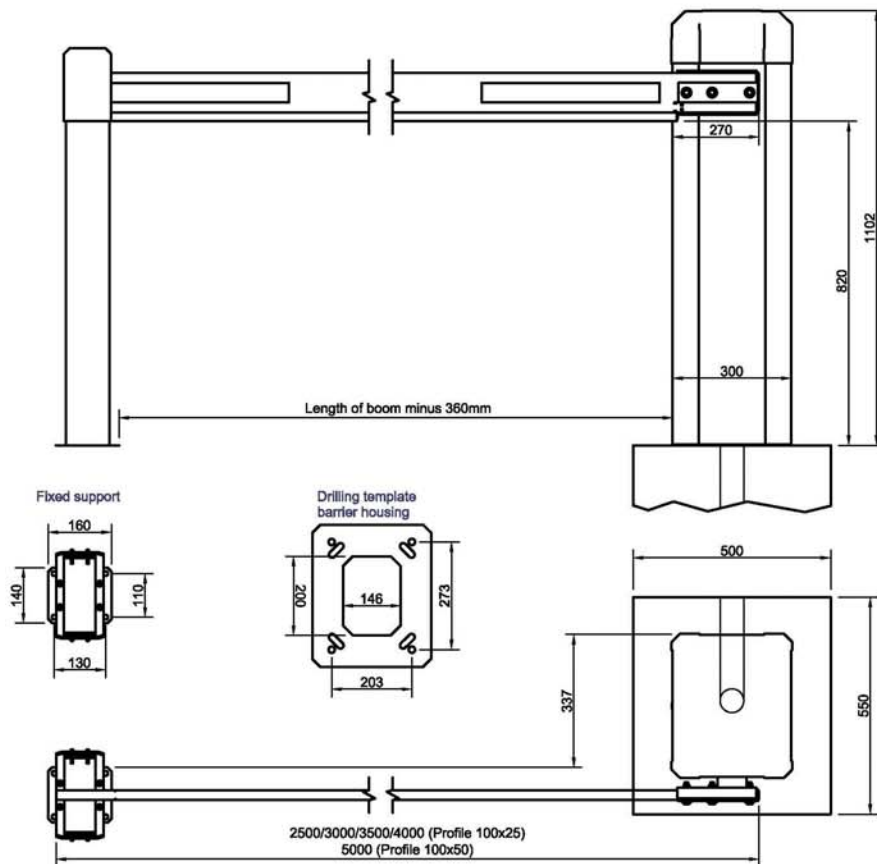
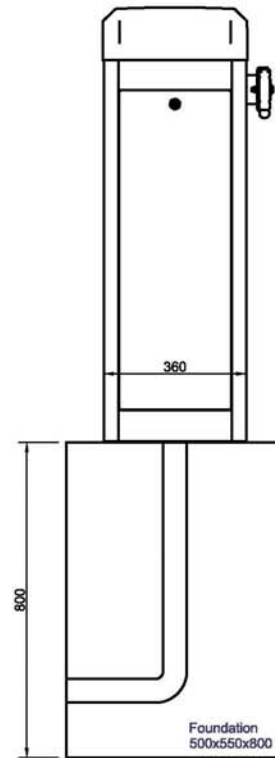

Drawing 3

7.3 Foundation

Basic requirements

- Keep a safety distance of min. 500mm between all moving barrier parts and surrounding objects like walls, fences etc. Please check the following drawing.
- When preparing the foundation consider the alignment and distance related to a (optional) fixed support (see drawing Drawing 3).

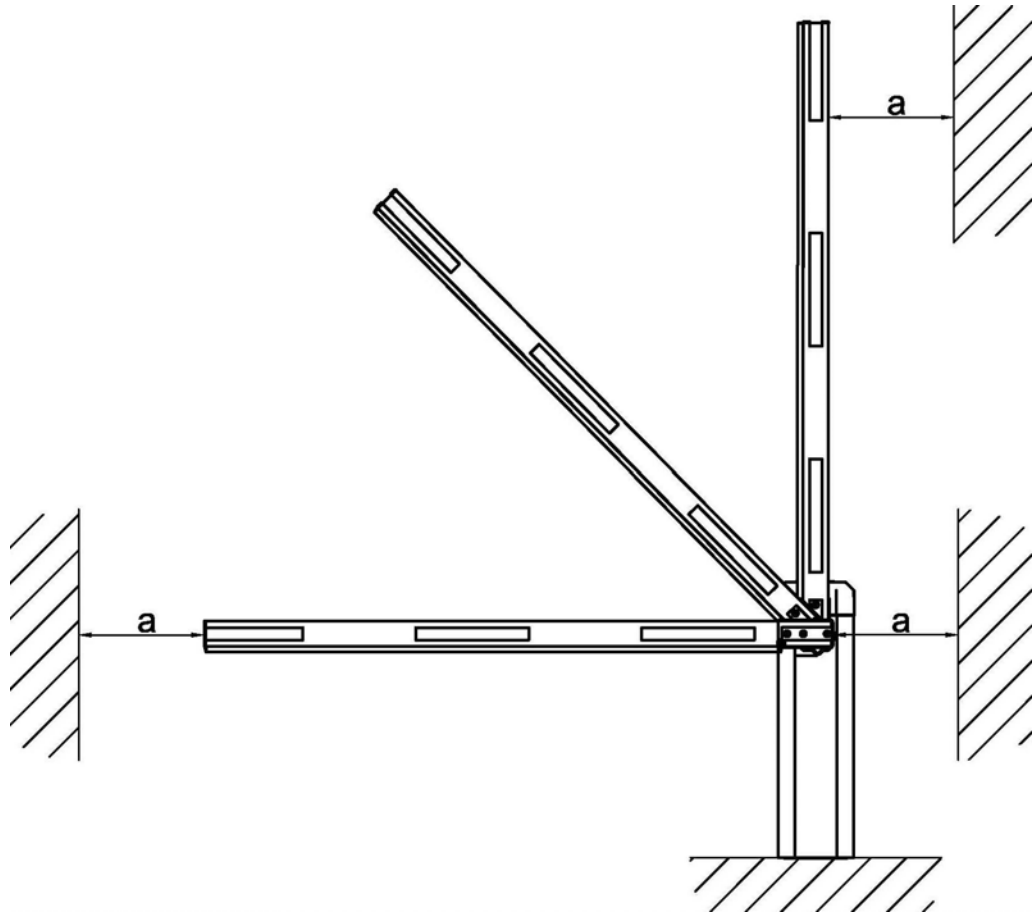

Drawing 4

a = min. 500mm

Empty conduits

- Use separate conduits for the power line and the control leads.
- Use an additional (separate) conduit for each induction loop.
- The distance between the conduits should be as large as possible.

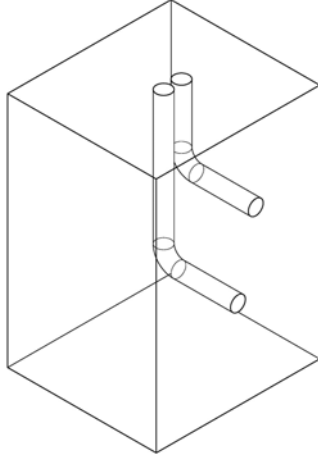

Drawing 5

Requirements regarding the foundation

- A minimum concrete strength class of C20/25 (or higher)
- The use of heavy duty anchor bolts (M12).
- Observe the foundation dimensions quoted in this manual. The installation distance between the barrier housing and the foundation edge has to be approx. 100mm.



WARNING!

Risk of injury by insufficient fastening!

Tilting barrier housings can result in severe injuries.

- Before installation ensure a safe stand of the barrier housing.
- Do not lean the barrier boom against a wall or similar before installation. Store the boom horizontally only.
- Install the barrier housing as specified.
- Use the recommended heavy duty anchor bolts M12, at least M10 is required.
- During maintenance check the housing for correct fastening on the foundation.

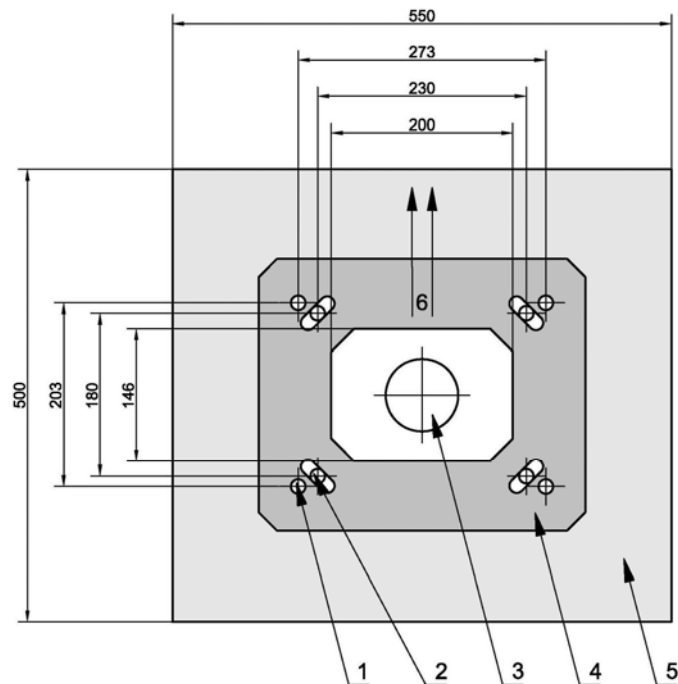

Drawing 6

- 1 Fastening point (273 x 203mm)
- 2 Fastening point, re-adjustable (230 x 180mm)
- 3 Clearance for cable entry (empty conduits) (200x146mm)
- 4 Drilling template
- 5 Foundation
- 6 Direction roadway

**WARNING!**

Danger of injury by incorrect fixation of the barrier housing on the foundation!

Loosening of the anchor bolts from the foundation.

- During the fastening of the barrier obey the minimum distance of the heavy duty anchor to the edge of the foundation.

7.4 Opening / closing the housing

**WARNING!**

Rotating and/or linear movable components can cause serious injuries.

Do not reach into moving parts or handle any moving components during operation.

- Turn the appliance off before any maintenance work, repair work or other work and secure it against unintentional restarting.



Open the housing with the access panel key. The key is located in the accessory box.

Removing the housing hood:

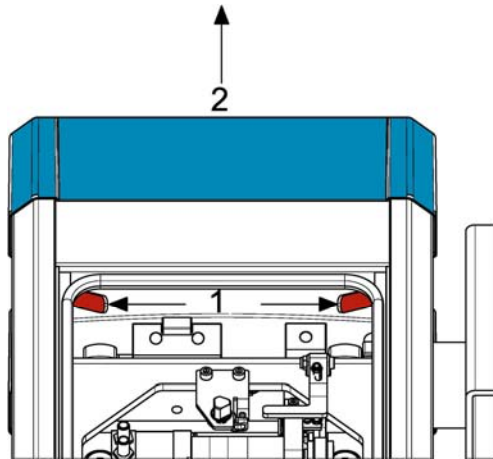

Drawing 7

1. Remove the hood by pressing the release levers to the outside (1). The hood raises itself.
2. Now take the hood off upwards - using both hands (2).

Installing the hood:

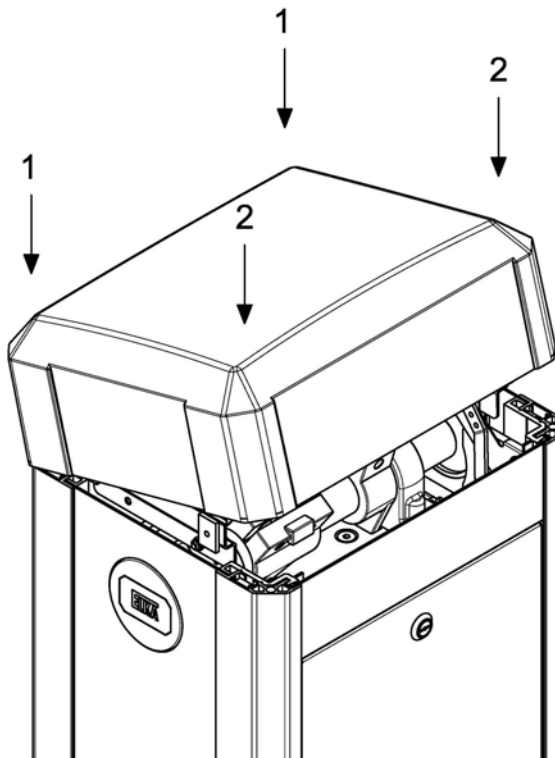

Drawing 8

1. Using both hands place the hood on the housing by first pressing the rear guidance points (1), then the front guidance points (2).
2. The hood snaps into place with an audible click.

7.5 Boom connector

1. The boom connector can be mounted left or right (factory setting is right). To fasten the boom connector, plug it without the clamping piece on the main shaft. Pay attention to a perfect fit of the shaft seal at the housing. Now connect the clamping piece using the four screws (M12x30 ISO4762). Tighten the screws only so far that an alignment of the boom connector on the main shaft is still possible.

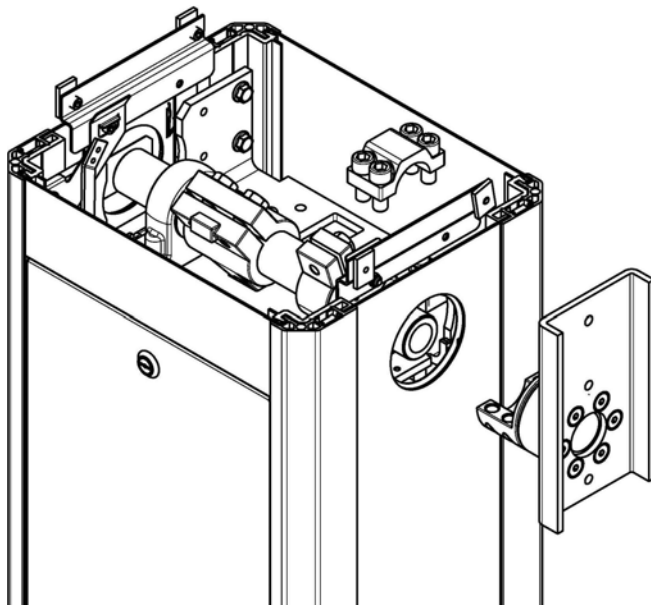

Drawing 9

2. The barrier mechanics is preset at the factory so that the barrier boom can perform a 90° - movement from the vertical to the horizontal position. The barrier is delivered in open (vertical) position. The drive lever is over the dead center at the mechanical stop (see drawing below). If necessary, correct the position by pulling the drive lever (1) in direction OPEN - towards access panel/roadway (arrow 2).

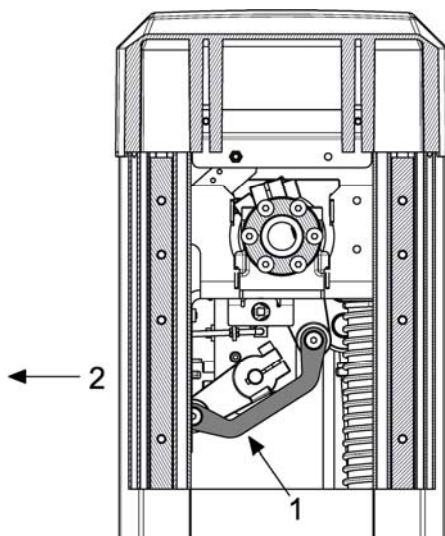

Drawing 10

3. Adjust the boom connector vertically using a water-level.

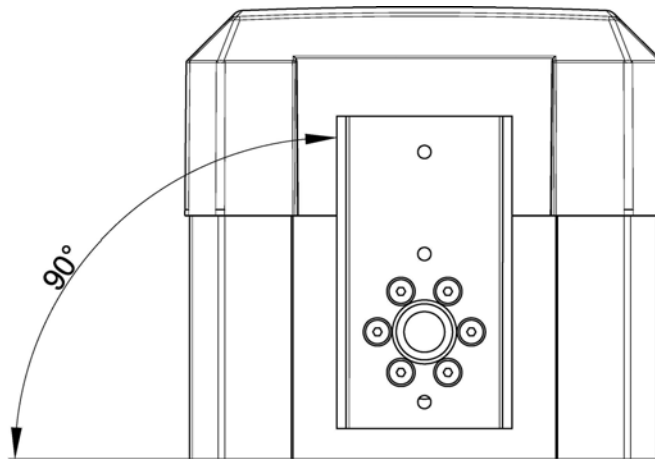

Drawing 11

4. Now retighten the four screws (M12x30 ISO 4762) at the clamping piece with 120Nm.

7.5.1 Installation – Boom connector left side

The barrier models TF 1203/0001-1204/0001 and XP 1203/0001-1204/0001 are prepared at the factory to mount the boom on the right side. At the left side a cap is mounted to cover the main shaft opening.

Converting from barrier boom right to barrier boom left:

1. Remove the barrier hood.
2. Detach the cover cap at the left housing side as described in the following drawing. First pull the spring sheet upwards (1), then turn the cover cap approx. 60° (2) and pull it upwards (3).

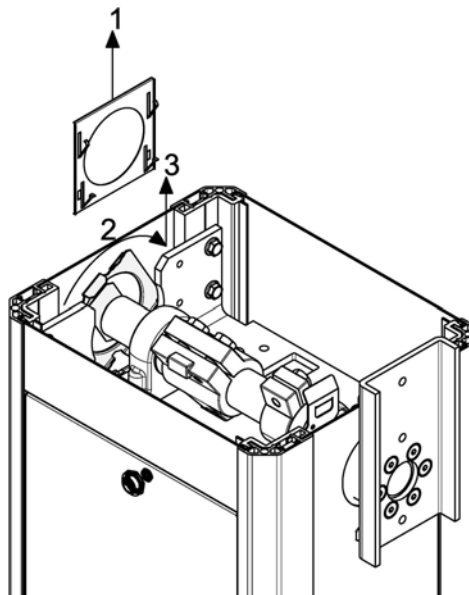

Drawing 12

3. Disconnect the boom connector from the right side, if already mounted. Connect it to the left side.
4. Mount the cover cap and the spring sheet at the right housing side.



All drawings, tables and descriptions in this installation manual refer to the factory-set (pre-) mounting of the boom holder at the right side.

7.6 Barrier boom

1. Remove all balancing springs from the spring assembly (see below drawing).

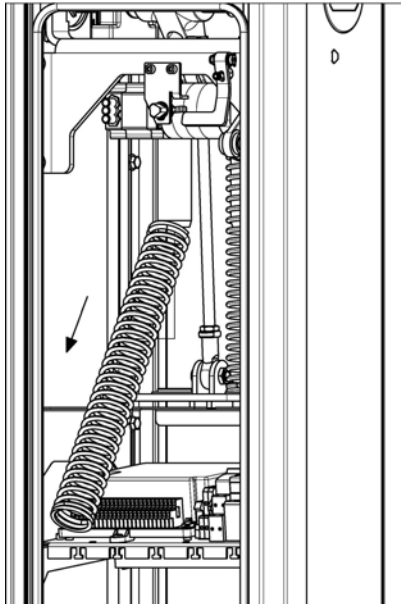

Drawing 13

2. Turn the barrier mechanics (at the boom connector) into position CLOSED (1). If necessary support the movement by pushing the drive lever in direction CLOSED (2).

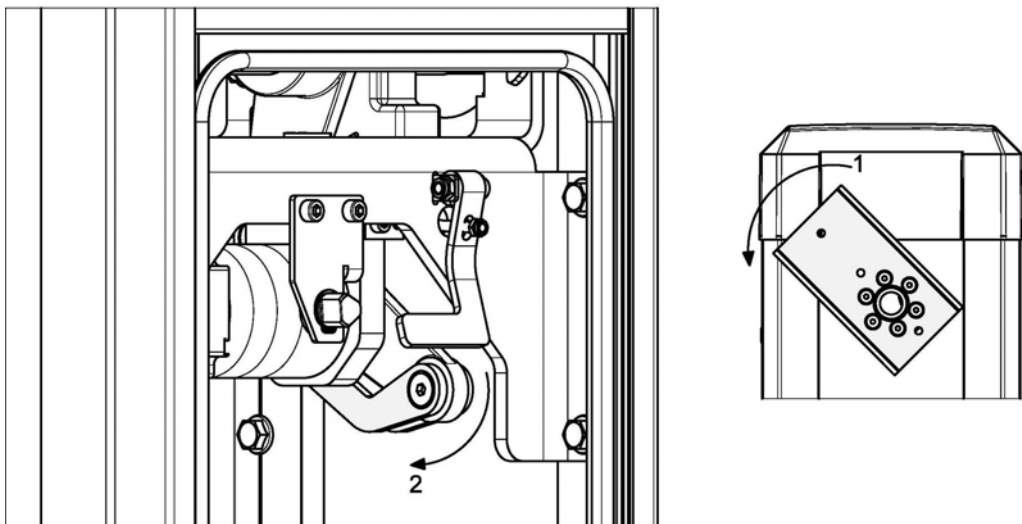

Drawing 14

3. Position the barrier boom with the reinforcement plate at the boom connector. Make sure that the profile of the barrier boom fits tightly (without play) at the boom connector.

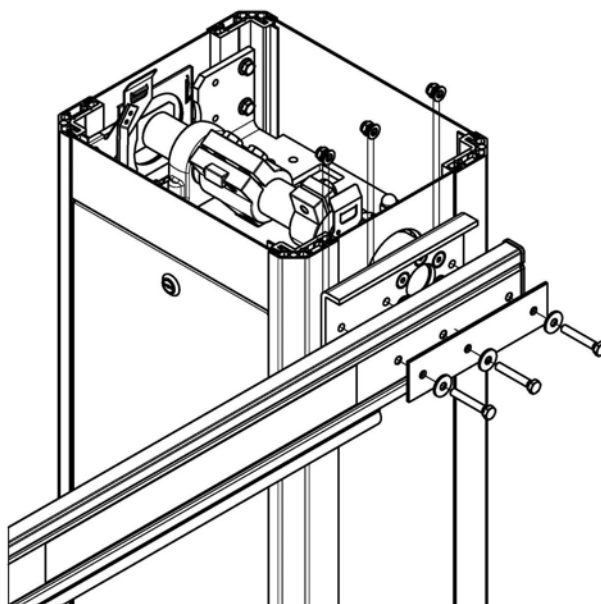

Drawing 15

4. **Barriers P 2500 - P 4000:**

Connect the barrier boom to the boom connector using the plastic screws M8x50. Tighten the fastening nuts with a max. torque of 1.8Nm.



Use only the specific plastic screws M8x50. Screws with another specification might prevent the tearing off of the barrier boom (predetermined shearing point).

5. **Barriers P 5000:**

Connect the barrier boom to the boom connector using the screws M8x70. Tighten the fastening nuts with a max. torque of 20Nm.



Due to the use of the steel screws M8x70 at the barrier P 5000 the predetermined shearing point and such the vandalism protection is not applicable – other than with the barriers P 2500 - P 4000.

7.7 Balancing springs

1. Activate the mechanical emergency release of the barrier and place the barrier boom manually in position OPEN.
2. Mount the number of balancing springs according to the boom length and additional (optional) equipment if applicable (see table below).



Please note that for the different versions two types of pressure springs (F1.1 and F1.2) are used.

	Boom length [mm]						
Model	2,000	2,500	3,000	3,500	4,000	4,500	5,000
P 2500	2x F1.1	2x F1.1	---	---	---	---	---
P 2500 with	2x	3x	---	---	---	---	---

Model	Boom length [mm]						
	2,000	2,500	3,000	3,500	4,000	4,500	5,000
articulated boom	F1.1	F1.1					
P 2500 with round boom	2x F1.1	2x F1.1	---	---	---	---	---
P 3000	2x F1.1	2x F1.1	3x F1.1	---	---	---	---
P 3000 with articulated boom	2x F1.1	3x F1.1	3x F1.1	---	---	---	---
P 3000 with round boom	2x F1.1	2x F1.1	2x F1.1	---	---	---	---
P 3500	2x F1.1	2x F1.1	3x F1.1	4x F1.1	---	---	---
P 3500 with articulated boom	2x F1.1	3x F1.1	3x F1.1	4x F1.1	---	---	---
P 3500 with round boom	2x F1.1	2x F1.1	2x F1.1	3x F1.1	---	---	---
P 4000	2x F1.1	2x F1.1	3x F1.1	3x F1.1	2x F1.2	---	---
P 4000 with swinging support	---	---	---	2x F1.2	2x F1.2	---	---
P 4000 with articulated boom	2x F1.1	2x F1.1	3x F1.1	4x F1.1	2x F1.2	---	---
P 4000 with round boom	2x F1.1	2x F1.1	2x F1.1	3x F1.1	3x F1.1	---	---
P 4000 with round boom and with swinging support	---	---	---	3x F1.1	2x F1.2	---	---
P 5000	---	---	---	2x F1.2	3x F1.2	3x F1.2	4x F1.2
P 5000 with swinging support	---	---	---	3x F1.2	3x F1.2	3x F1.2	4x F1.2

Table 6

Pressure spring type F1.1 = Balancing spring

Wire diameter 5mm

For barriers up to 3,500mm boom length

Pressure spring type F1.2 = Balancing spring
Wire diameter 6mm
For barriers above 3,500mm boom length

3. During installation of the balancing springs please observe the correct positioning in the spring assembly (see drawing below – positions of the pressure springs on the support plate).

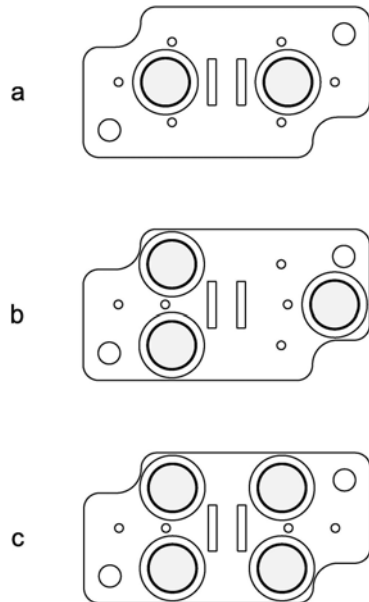

Drawing 16

- a = 2 springs
b = 3 springs
c = 4 springs



It is not permitted to operate the barrier with only one spring mounted!

4. Activate the mechanical emergency release of the barrier and place the barrier boom manually in position 45°. The barrier boom has to level itself in this position. If necessary, correct the boom position by tightening/loosening of the spring tension.

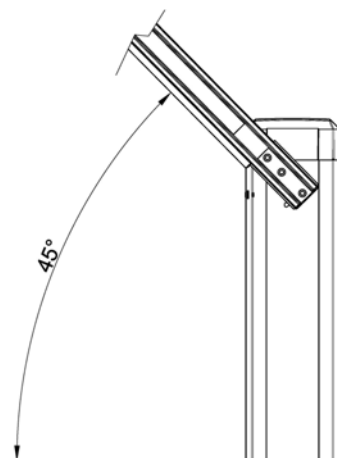

Drawing 17

Adjusting the spring tension:



WARNING!

Danger of impact and crushing!

During the barrier movement, energy is saved in the springs. The springs are not tight and thus energy-free only in barrier position OPEN.

- Mount and dismount the springs in barrier position OPEN only. If necessary open the barrier by mechanical emergency release and move the barrier manually into position OPEN.



WARNING!

Risk of crushing

During the barrier movement crushing points arise at many points of the barrier mechanics.

- Before installation, maintenance or repair work at the barrier mechanics turn the power supply off and secure it against unintentional restarting.

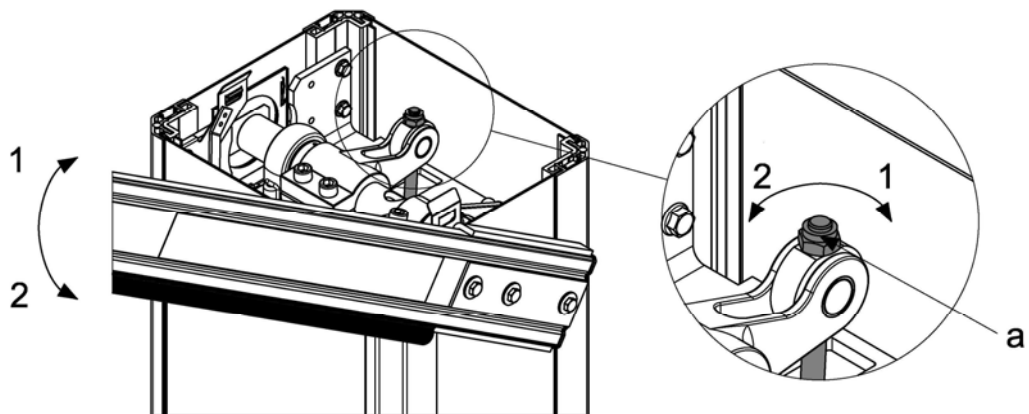

Drawing 18

Tightening the spring tension: Turn the clamping nut (a) clockwise (1). The boom moves in direction (1).

Loosening the spring tension: Turn the clamping nut (a) anti-clockwise (2). The boom moves in direction (2).

7.8 Opening and closing times



The opening and closing times of the barriers are factory-set to standard values based on the model:

- P 2500 = approx. 1.3 seconds
- P 3000 = approx. 1.8 seconds
- P 3500 = approx. 2.5 seconds
- P 4000 = approx. 3.8 seconds
- P 5000 = approx. 4.5 seconds



The opening and closing times of the barriers can be changed in the learning sequence of the controller MO 24 under sequence point P101.

- Sequence point P101 = 0 = fast
- Sequence point P101 = 1 = standard (factory setting)
- Sequence point P101 = 2 = slow

Model-related data	P 2500	P 3000	P 3500	P 4000	P 5000
Running time –slow [s]	approx. 1.8	approx. 2.5	approx. 3.8	approx. 4.5	approx. 5.5
Running time –standard [s]	approx. 1.3	approx. 1.8	approx. 2.5	approx. 3.8	approx. 4.5
Running time – fast [s]	approx. 0.9	approx. 1.3	approx. 1.8	approx. 2.8	approx. 3.8

Table 7

7.9 Accessories

7.9.1 Swinging support P 4000 - P 5000

1. Move the barrier boom into the horizontal position.

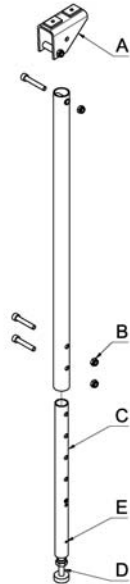

Drawing 19

2. The bottom part 'C' can be connected at the approximate length using the screws 'B'.
3. Remove approx. 1,000mm of the rubber tube under the boom and push the securing pieces 'A' of the swinging support into the notch of the barrier boom. Secure the swinging support using the two hexagon head screws.

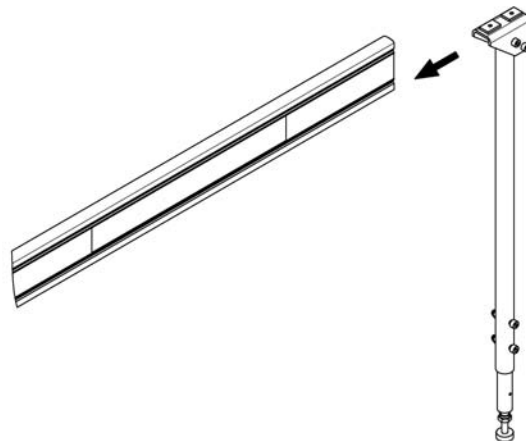

Drawing 20

4. Push the rubber tube back into the notch and cut off the protruding part.
5. A fine adjustment of the swinging support height can now be made at the foot 'D'.
6. Screw an M4mm screw into the whole 'E' and loosen the M10 stop nut at the foot 'D'.
7. The foot can now be screwed to the appropriate position. Tighten the M10 stop nut upwards against the aluminium bushing. Remove the M4 screw.

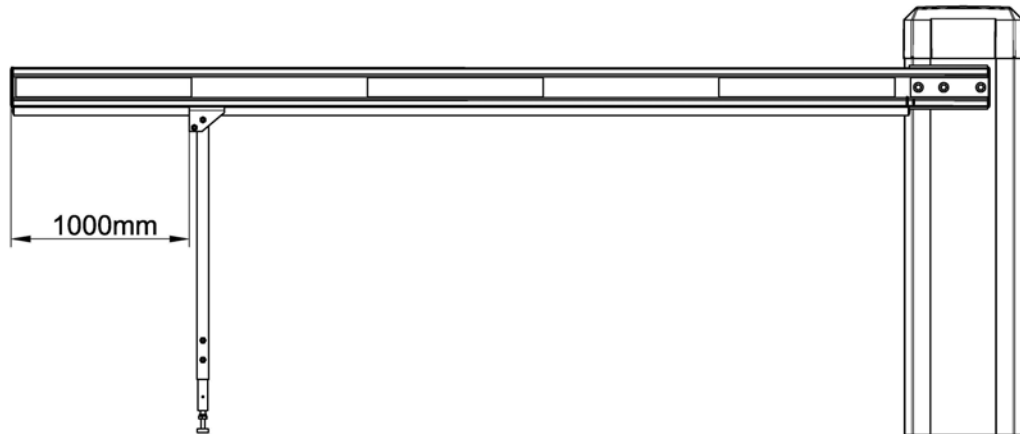

Drawing 21



Due to the additional load of the swinging support, the number of balancing springs has to be adjusted. Install the correct number of balancing springs depending on the boom length according to the table on page 26

7.9.2 Fixed support P 4000 - P 5000

1. Mount the fixed support on a suitable foundation.
2. Observe the alignment and the distance to the barrier (see drawing below).
3. Mount the fixed support on the foundation.
4. Pay attention to the following points during installation. When the barrier is closed:
 - a. the barrier boom has to be positioned in the middle of the support fork.
 - b. the profile end of the barrier boom must not protrude beyond the support fork.
 - c. the barrier boom remains approx. 2-3cm above the rubber insert.

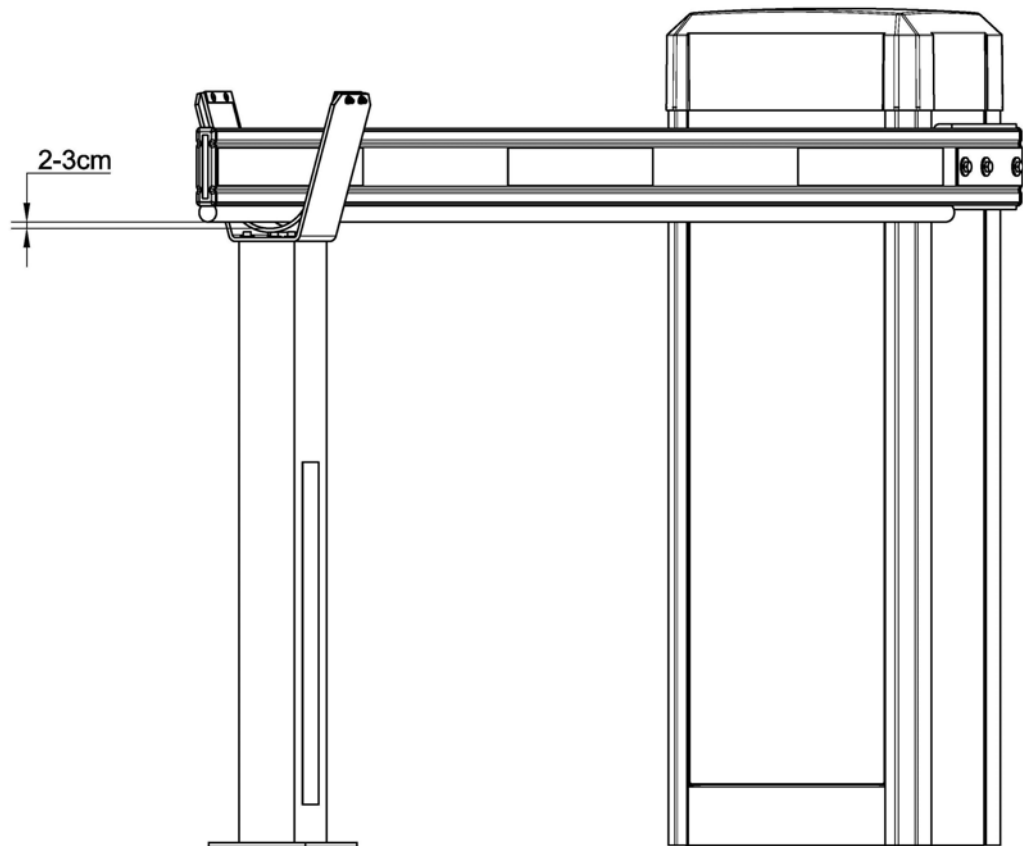

Drawing 22

7.9.3 Fixed support with electromagnet P 4000 - P 5000

1. Mount the fixed support on a suitable foundation.
2. Observe the alignment and the distance to the barrier (see drawing below).
3. Mount the fixed support on the foundation.

Mounting the anchor plate to the barrier boom:

1. Connect the flexible lead from the magnet with the cable of the barrier.
There is enough room at the lower part of the support for a junction box.
2. Fit the support fork onto the foot and secure it at the required height.
3. Remove a part of the rubber profile from the bottom part of the boom.
4. Push one of the securing pieces into the notch of the closed barrier boom.
5. Now insert the anchor plate into the notch until it is exactly above the magnet.

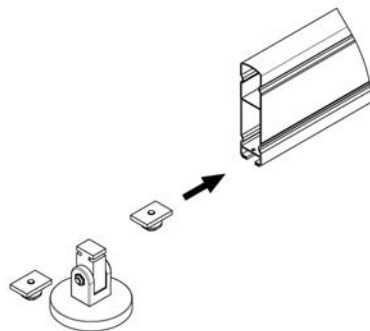

Drawing 23

6. Now insert the second securing piece.
7. Push both securing pieces against the anchor plate and secure them with the screws.

Connecting the electromagnet in the barrier:

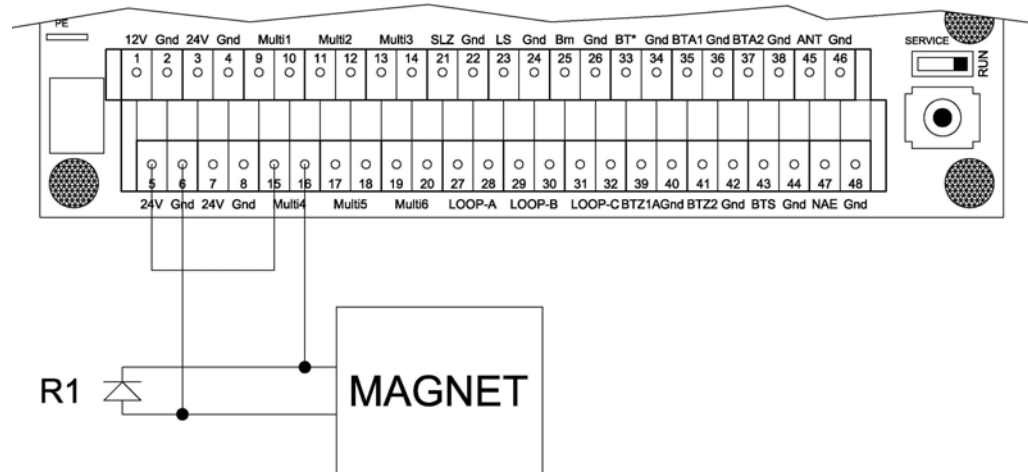

Drawing 24

Following the connection of an electromagnet as well as the required parameter changes in the controller are described. As an example the multi-functional relay 4 (MULTI4) and as power supply for the standard electromagnet the internal 24Vdc of the MO 24 is used.



CAUTION!

Over-voltage when switching off an inductive DC load!

Defect of the controller or the external (on-site) DC voltage source by overvoltage!

- Always connect the free-wheeling diode R1 (type 1N4004), as shown in the drawing, when using an electromagnet.

1. Connect the electromagnet to the terminal row, as shown in the drawing. Use a minimum cable cross-section of 1.5mm². The cable length shall not exceed a length of 20m.
2. Connect the multi-functional relay 4 to 24Vdc.
3. Activate the pre-warning time in the learning sequence of the controller MO 24 under sequence point P302. Select a time longer than 1.5 seconds.
4. Activate the multi-functional relay 4 in the learning sequence under sequence point P504. Select the operating mode "10" - The multi-functional relay is activated, when the barrier is closed. During the pre-warning before opening the relay is already switched off.

Procedure:

1. The barrier is closed. On receipt of a signal to open the multi-relay is switched off and it loses the residual magnetism during the pre-warning time.
2. The barrier opens after the set pre-warning time (P302) has elapsed.
3. The barrier is open. After a closing impulse the multi-functional relay (the magnet) is switched on only when the end position CLOSED is reached.

7.9.4 LED boom lighting

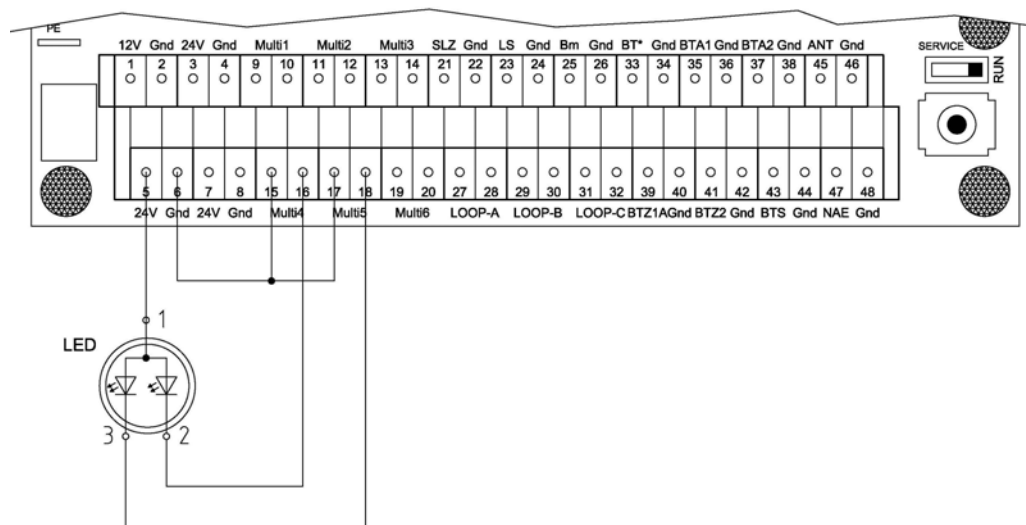

Drawing 25

The following instruction explains the connection of the LED boom lighting as well as the necessary parameter changes in the controller. As an example the multi-functional relay 4 (MULTI4) and the multi-functional relay 5 (MULTI5) are being used for the activation as well as the internal 24Vdc power supply of the controller MO 24 as power supply.

1. Connect the supply line of the LED boom lighting to the terminal row X1, as shown in the drawing. Use a min. wire cross section of 0.5mm².
2. Connect the multi-functional relays 4 and 5 to ground (Gnd) as shown.
3. Activate the multi-functional relay 4 under the sequence point P504 in the learning sequence of the controller. Select the operating mode "9". The multi-functional relay is activated when the barrier is open. During pre-warning before closing the relay is already deactivated.
4. Activate the multi-functional relay 5 under the sequence point P505 in the learning sequence of the controller. Select the operating mode "10". The multi-functional relay is activated when the barrier is closed. During pre-warning before opening the relay is already deactivated.

Procedure:

1. The barrier is closed. The LED boom lighting is RED. When an opening impulse is given, the multi-functional relay 4 is switched off.
2. The barrier opens. The LED boom lighting is off.
3. The barrier is open. The LED boom lighting is GREEN. When a closing impulse is given, the multi-functional relay 5 is switched off.

7.10 Emergency release

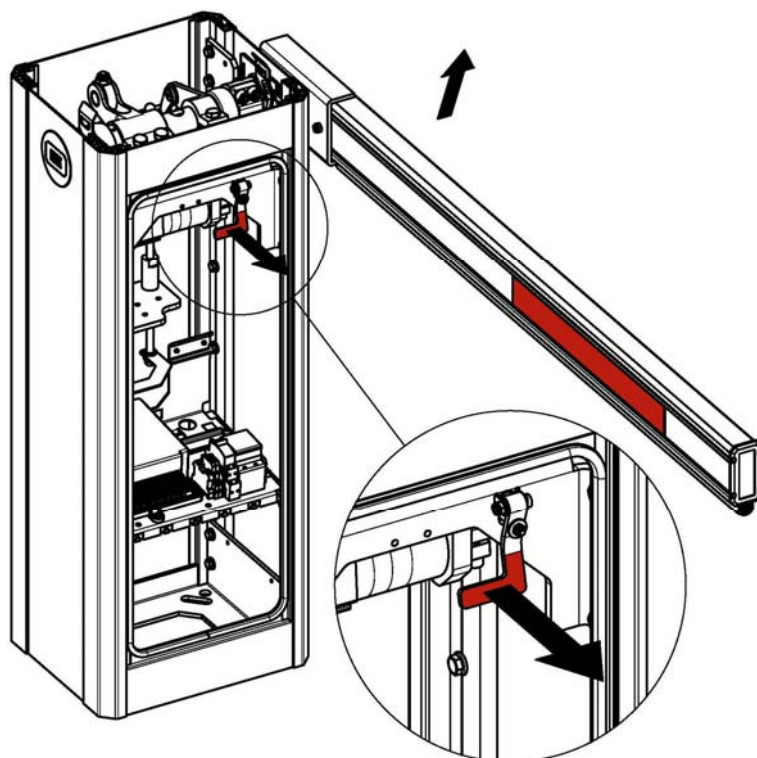

Drawing 26

During a power failure open the barrier by pulling the release lever. Now, the barrier can be opened by hand.

7.11 Vandalism



WARNING!

By pressing the boom up or down the correct position of the boom may be moved (missadjusted - vandalism!). Unforeseeable danger spots may arise.

- If the position of the boom is misadjusted, the correct setting of the barrier boom must be restored.

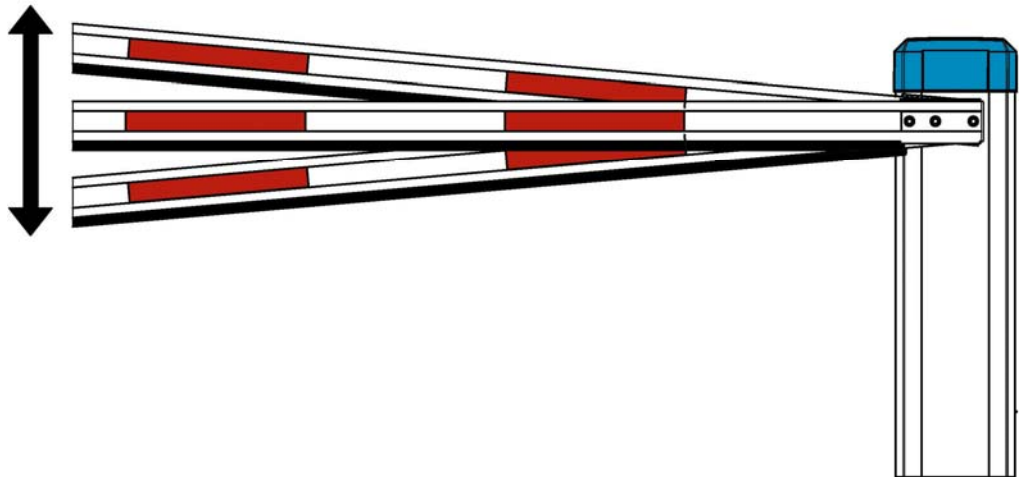

Drawing 27



WARNING!

Rotating and/or linear movable components can cause serious injuries.

Do not reach into moving parts or handle any moving components during operation.

- Turn the appliance off before any maintenance work, repair work or other work and secure it against unintentional restarting.



WARNING!

Danger due to uncontrolled movements of the mechanics by pre stressed springs!

Parts of the mechanics can move through the spring tension and pinching body parts.

- **BEFORE adjusting the boom position, the barrier boom must be moved electrically or by hand (emergency release) in the position OPEN.**

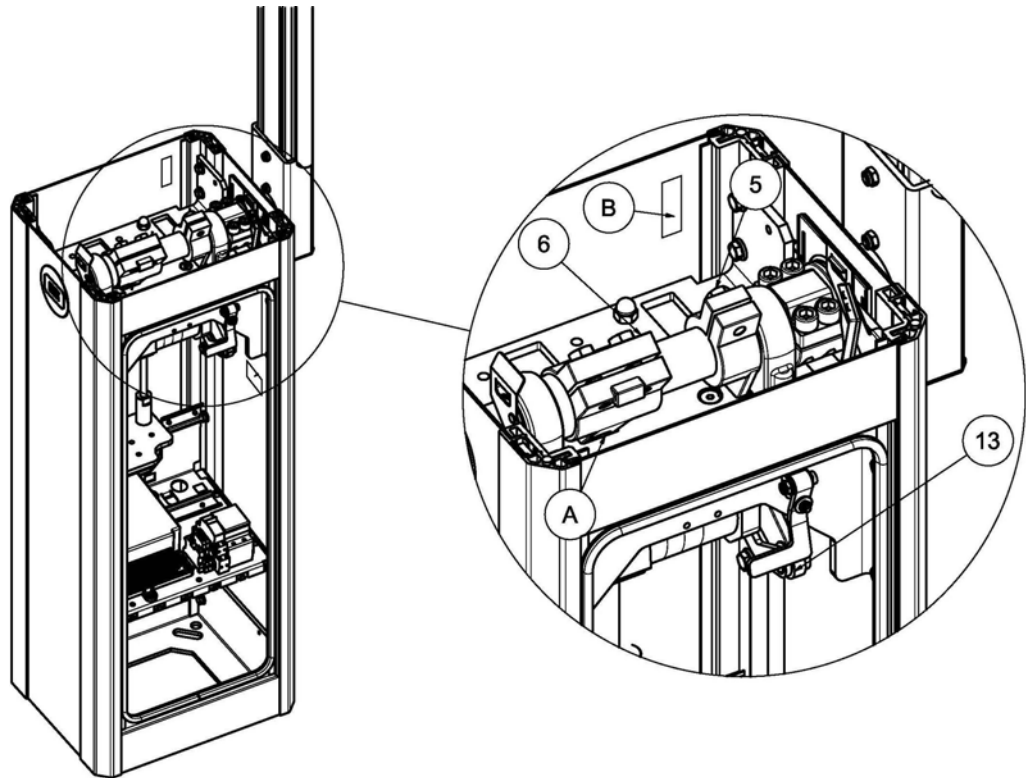

Drawing 28

Restoring of the correct barrier boom position

1. Loosen the clamping screw of the drive lever M (Pos. 5).
2. Set manually the boom in position OPEN.
3. Rotate the gear box shaft (Pos. 13) up to the stop.
4. A distance (A) of 2mm must be set between the drive lever F and the cut in the main plate. If this is not the case, loosen the two clamp bolts of the drive lever F and set the distance to about 2mm. Tighten the clamping screws of the drive lever F (120Nm).

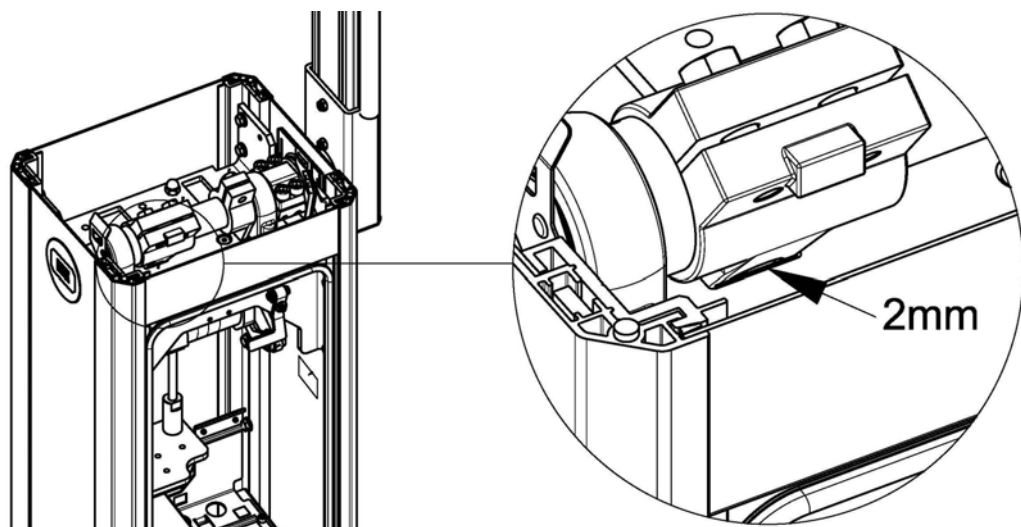

Drawing 29

5. Tighten the clamping screw of the drive lever M to the specified torque. The torque is adapted to the mechanics and is marked on the label (B).
6. Turn on the barrier (power supply). Check the faultless running and the correct positions (OPEN and CLOSE).

8 Terminal row

8.1 Interior view

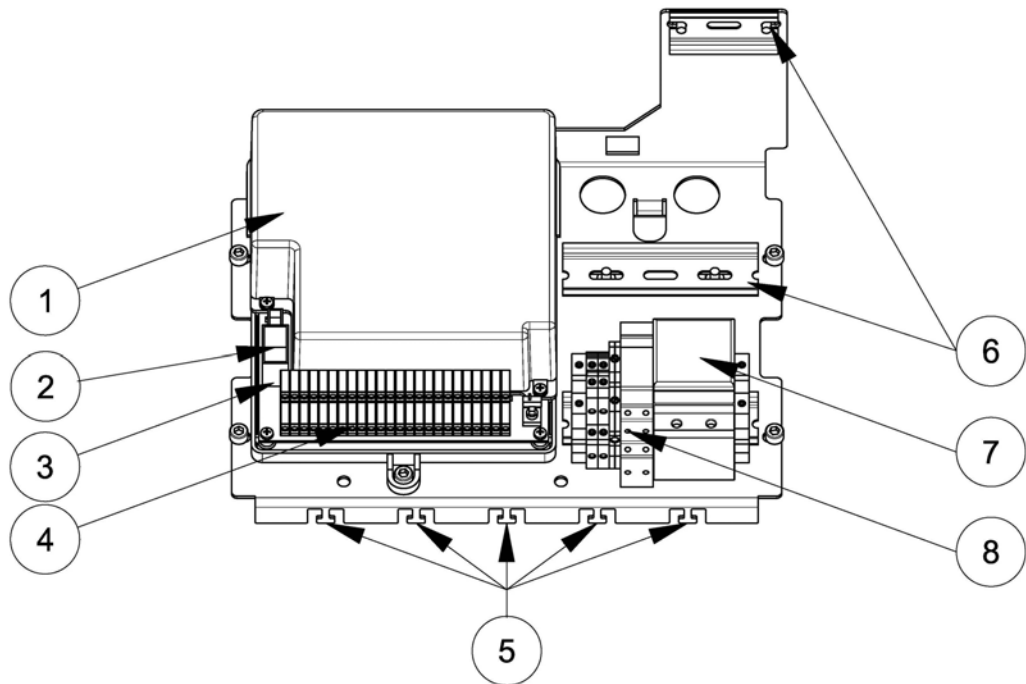

Drawing 30

Pos.	Description
1	Controller MO 24 (with housing and cover)
2	Supply voltage 24VDC
3	Motor connection
4	Terminal row
5	Fixing clamp for power- and signal lines
6	Top hat rail for accessories (optional or on-site)
7	Maintenance mains power outlet
8	Power supply with on-off switch

Table 8

8.2 Mains connection



WARNING!

Danger through voltage!

Danger of an electric shock.

- Only certified electricians (VDE 0100) should connect the controller to the mains supply.

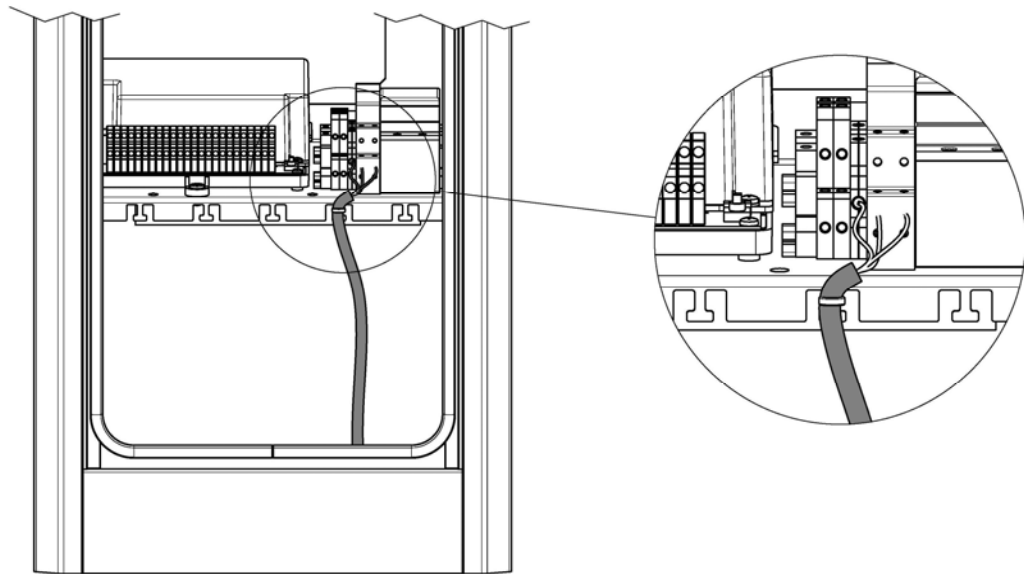

Drawing 31

Connecting the power line:

1. Lay the power line via the shortest possible way to the main switch. Make sure the power line does not have contact with any movable mechanical parts.
2. Connect the power line to the main switch and to the earth lead terminal.
3. Fasten/secure the power line by cable ties at the provided tabs.

8.3 Controller terminal row

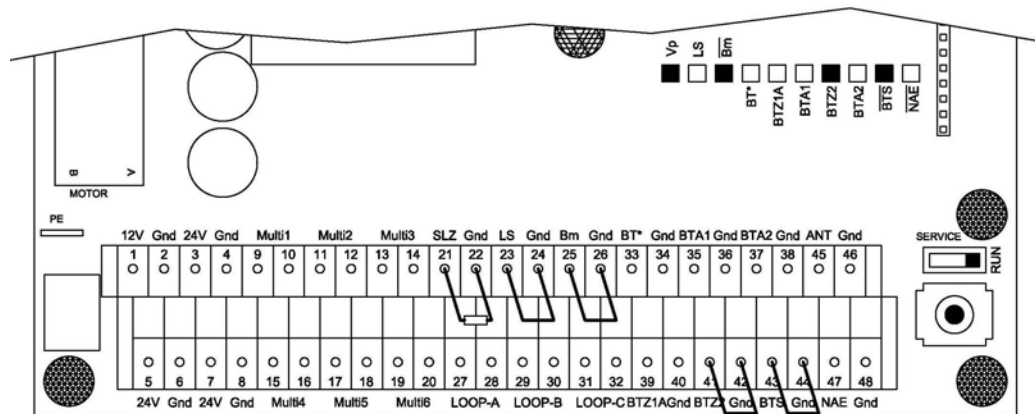

Drawing 32

The following control inputs have to be bridged or occupied with contact (NC) for operation:

1.	Terminals 23 + 24	Photoelectric barrier (LS)	NC contact or bridge
2.	Terminals 25 + 26	Boom missing contact (Bm)	NC contact or bridge
3.	Terminals 41 + 42	Push button CLOSE (BTZ2)	NC contact or bridge
4.	Terminals 43 + 44	Push button STOP (BTS)	NC contact or bridge

5.	Terminals 21 + 22	Safety contact profile CLOSE (SLZ)	8.2kOhm resistor
----	----------------------	------------------------------------	---------------------

Table 9

After installing and connecting all the equipment, the following LEDs have to light:

1.	Vp	Is lit, when the supply voltage is switched on.
2.	BTZ2	Is lit, when contact BTZ2 is closed.
3.	BTS	Is lit, when contact BTS is closed.
4.	Bm.	Is lit, when the boom-missing contact is closed.

Table 10

Plug	Socket label	Function
1	12V	Uext 12V, max. 500mA
2	Gnd	Ground
3	24V	Uext 24V, in total with terminal 5 and 7 max. 1500mA
4	Gnd	Ground
5	24V	Uext 24V, in total with terminal 3 and 7 max. 1500mA
6	Gnd	Ground
7	24V	Uext 24V, in total with terminal 3 and 5 max. 1500mA
8	Gnd	Ground
9	Multi1	Multi-functional relay 1, potential-free, max. 24VDC/1A
10		
11	Multi2	Multi-functional relay 2, potential-free, max. 24VDC/1A
12		
13	Multi3	Multi-functional relay 3, potential-free, max. 24VDC/1A
14		
15	Multi4	Multi-functional relay 4, potential-free, max. 24VDC/1A
16		
17	Multi5	Multi-functional relay 5, potential-free, max. 24VDC/1A
18		
19	Multi6	Multi-functional relay 6, potential-free, max. 24VDC/1A
20		
21	SLZ	Safety contact profile CLOSE, 8.2kOhm
22	Gnd	Ground
23	LS	Photoelectric barrier (NC contact)

Plug	Socket label	Function
24	Gnd	Ground
25	Bm	Boom-missing contact
26	Gnd	Ground
27	LOOP-A	Induction loop A
28		
29	LOOP-B	Induction loop B
30		
31	LOOP-C	Induction loop C
32		
33	BT*	Configurable input: BT or BTA3 or BTZ1B (NO contact)
34	Gnd	Ground
35	BTA1	Push button OPEN 1 (NO contact)
36	Gnd	Ground
37	BTA2	Push button OPEN 2 (NO contact)
38	Gnd	Ground
39	BTZ1A	Push button CLOSE 1A (NO contact)
40	Gnd	Ground
41	BTZ2	Push button CLOSE 2 (NC contact)
42	Gnd	Ground
43	BTS	Push button STOP (NC contact)
44	Gnd	Ground
45	ANT	Antenna
46	Gnd	Ground
47	NAE	Power failure detection (ANAE)
48	Gnd	Ground

Table 11

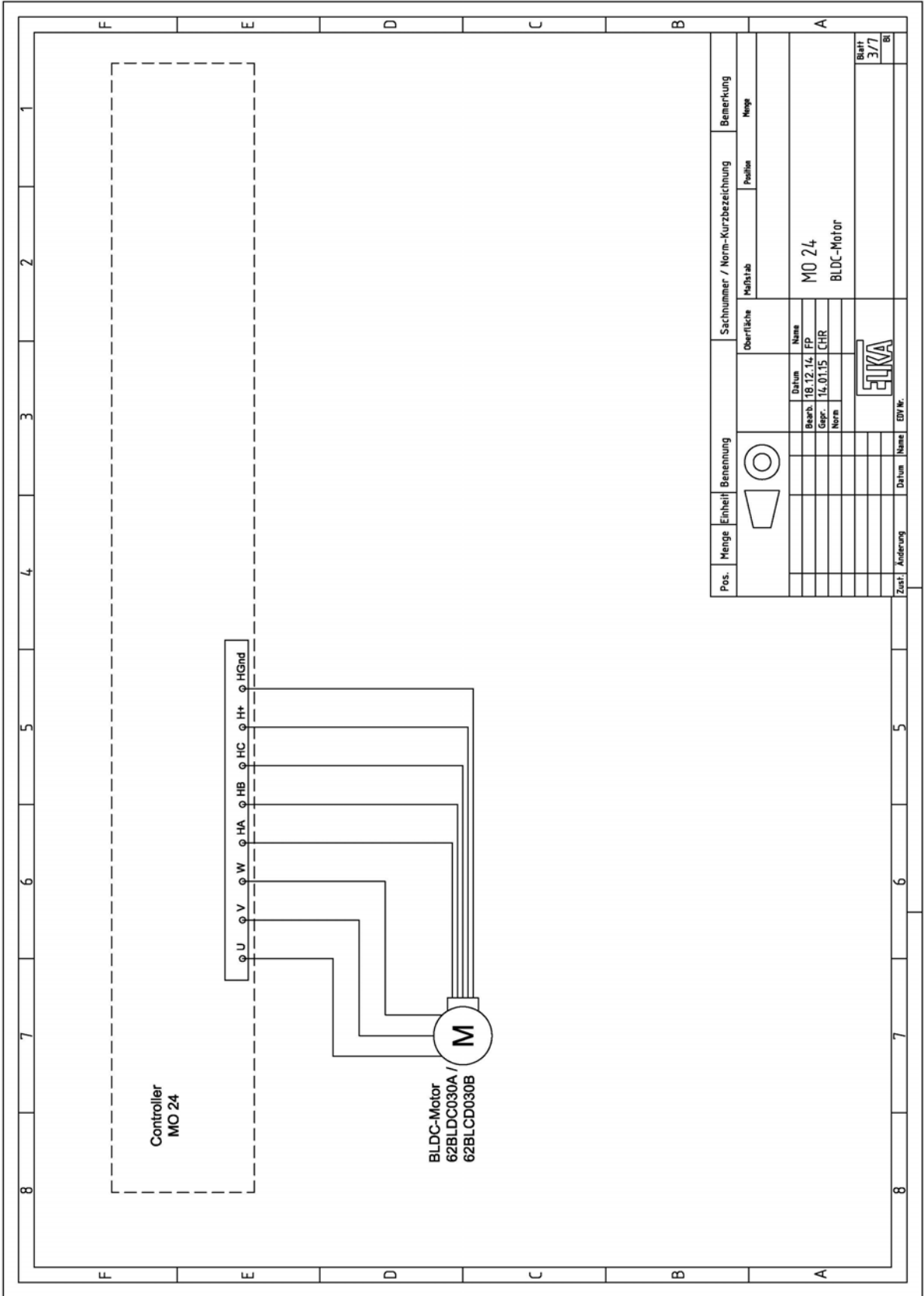

Drawing 35

Pos.	Menge	Einheit	Benennung	Sachnummer / Norm-Kurzbezeichnung		Bemerkung										
				Meßstab	Position											
					MO 24											
					BLDC-Motor											
				<table border="1"> <tr> <th colspan="2">Oberfläche</th> </tr> <tr> <td>Datum</td> <td>Name</td> </tr> <tr> <td>Bearb. 18.12.14</td> <td>FP</td> </tr> <tr> <td>Gepr. 14.01.15</td> <td>CHR</td> </tr> <tr> <td>Norm</td> <td></td> </tr> </table>		Oberfläche		Datum	Name	Bearb. 18.12.14	FP	Gepr. 14.01.15	CHR	Norm		
Oberfläche																
Datum	Name															
Bearb. 18.12.14	FP															
Gepr. 14.01.15	CHR															
Norm																
				<table border="1"> <tr> <th>Zust.</th> <th>Änderung</th> <th>Datum</th> <th>Name</th> <th>EDV Nr.</th> </tr> <tr> <td> </td> <td> </td> <td> </td> <td> </td> <td> </td> </tr> </table>		Zust.	Änderung	Datum	Name	EDV Nr.						
Zust.	Änderung	Datum	Name	EDV Nr.												
						<table border="1"> <tr> <td>Blatt</td> <td>3/7</td> </tr> <tr> <td>Bl</td> <td></td> </tr> </table>	Blatt	3/7	Bl							
Blatt	3/7															
Bl																

9 Barrier maintenance



WARNING!

Rotating and/or linear movable components can cause serious injuries.

Do not reach into moving parts or handle any moving components during operation.

- Turn the appliance off before any maintenance work, repair work or other work and secure it against unintentional restarting.

Maintenance P 2500-5000

The maintenance intervals must be decided individually as they are dependent on the application and the frequency of use. We recommend maintenance at least once every six months.

1. Check the balancing springs. In case of a faulty spring, all springs must be replaced simultaneously.
2. Check that the boom is perfectly balanced by the springs (see page 25).
3. Check barrier housing and boom for accidents and damage and replace where necessary.
4. Ensure that the potential earthing cable is still connected to the housing and to the door.
5. Check that the operating instructions are complete.
6. Check that all safety equipment works properly (induction loops, photoelectric barriers, power reversal,...).
7. Check that the barrier is still secure on the foundation.
8. Check the plastic screws (M8x45) or steel screws (M8x70) at the boom connector.
9. Check the emergency release for correct functioning (by activation).
10. Perform a visual inspection and tighten screws where necessary.
11. Grease the guide bars using multi-purpose grease (temperature range - 30°C to +70°C / -22°F to +158°F). Remove excess grease.

10 Layout (exploded drawing)

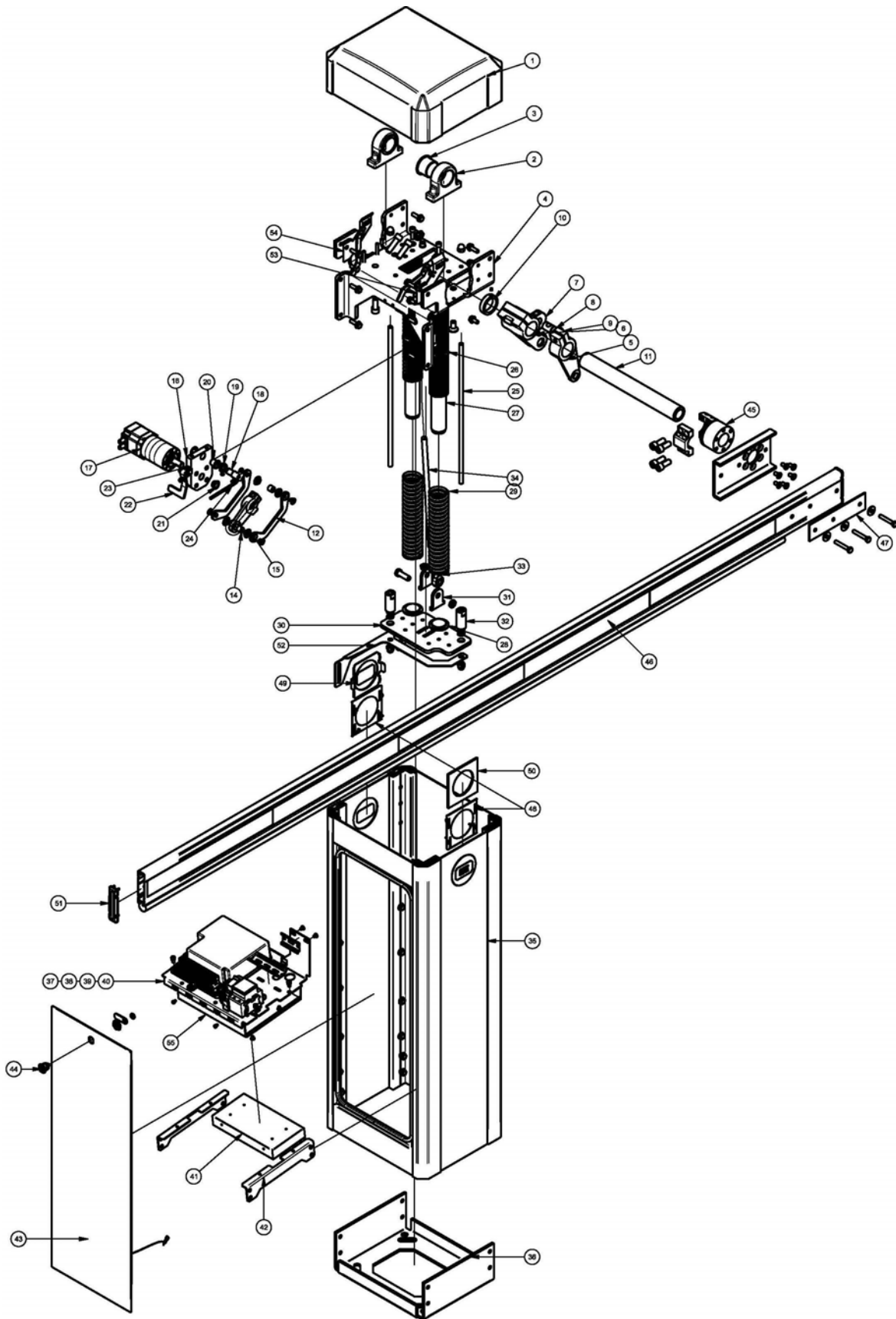

Drawing 40

Pos.	Qty.	Part name
1	1	Hood
2	2	Pillow block
3	2	Plain bearing, main shaft
4	1	Main plate
5	1	Drive lever M
6	1	Drive lever F
7	1	Tension lever - holder T1
8	1	Tension lever - holder T2
9	2	Plain bearing, spring holder
10	1	Distance ring
11	1	Main shaft
12	2	Connecting lever
13	1	Gearbox shaft
14	2	Cylinder bolt, mechanics
15	4	Plain bearing, mechanics
16	1	Bearing plate
17	1	BLDC-Motor / planetary gear
18	1	Eccentric tappet, releasing device
19	1	Spring, releasing device
20	1	Plain bearing, eccentric tappet (releasing device)
21	1	Plain bearing, gearbox
22	1	Lever, emergency release
23	1	Bracket, emergency release
24	2	Rod, emergency release
25	2	Guide bar
26	2	Spring plate
27	2	Spring guide
28	2	Spring holder
29	1	Pressure spring (F1.1 / F1.2)
30	2	Support plate P
31	1	Pull plate P
32	1	Plain bearing, flange bearing
33	1	Joint head 12R
34	1	Tension lever
35	1	Housing
36	1	Base plate
37	1	Controller MO 24, board

Pos.	Qty.	Part name
38	1	Mounting plate
39	1	Top had rail with on-off switch and terminals
40	1	Controller MO 24, housing
41	1	Power-supply unit
42	1	Bracket, mounting plate
43	1	Access panel
44	1	Lock cylinder with nut and lock bolt
45	1	Boom holder
46	1	Boom
47	1	Mounting kit boom with boom reinforcement
48	1	Supporting plate for seal or sealing cap
49	1	Sealing cap, housing
50	1	Felt seal
51	2	Boom end cap
52	1	Bracket, spring assembly
53	1	Hood sheet, housing, right
54	1	Hood sheet, housing, left

Table 12

Index

B		Mounting dimensions..... 17
Balancing springs..... 25		
C		N
Circuit diagram 43		Notes on safety for the operation..5
E		O
Emergency release 35		Opening and closing times29
F		P
Fixed support 31		Personal protective equipment7
Fixed support with electromagnet 32		plastic screws50
Foundation 18		R
Function description 13		radio remote control.....5
G		S
General notes on safety 5		Specialist7
I		Storing9
Installation 16		Swinging support30
Instructed person 7		Symbol explanation4
L		T
Layout (exploded drawing)..... 51		Technical data P 2500-5000..... 14
LED boom lighting..... 34		Terminal row39
M		Tools 16
Maintenance..... 50		Transportation and storing.....9
		Transportation inspection9
		V
		Vandalism36